



"Setting The Standard For Supplier Excellence"

VibraRod™ Vibratory Type Point Level Sensors For Solids

- ▼ Single-Probe Vibrating Rod Design
- ▼ Used for Wide Range of Powders and Other Bulk Solids
- ▼ Easy Setup – No Calibration
- ▼ Universal Power Supply
- ▼ Variety of Probe Configurations





- ▼ **Single Probe Vibrating Rod Design Used For Most Solids**
- ▼ **No Clogging/Bridging Like Tuning Fork Designs**
- ▼ **Unaffected by Environmental & Material Changes – No Calibration**
- ▼ **Pipe & Cable Extension Units Available**
- ▼ **Standard Version with Plastic or Aluminum Enclosure**
- ▼ **Hazardous Location Approvals**

The **VibraRod™** vibrating rod sensor provides reliable point level sensing in a wide variety of applications within powder and bulk solids markets. The vibrating probe principle utilized by the **VibraRod** overcomes typical application difficulties associated with changes in material, electrical dielectric constant, temperature or humidity while providing reliable solid state electronic circuitry that requires no calibration. The **VibraRod** has the ability to detect a wide range of material densities.

The **VibraRod** line of vibrating rod point level sensors is offered in standard length, cable extension or pipe extension versions. The standard length version extends into your vessel approximately 9 inches (235 mm). The pipe extended version can be used to extend the measuring rod up to 120 inches (3 m) and the cable extended unit can be used to extend the probe up to 65 feet (20 m). Each version can be provided with either a plastic or aluminum housing. **VibraRod** units are provided with local indication using a bi-color LED and a traditional relay output.

PRINCIPLE OF OPERATION

The **VibraRod™** line of point level sensors is a mechanical resonance system that is excited and kept in resonance by the sensor's electronic circuitry. Two piezoelectric crystals are mounted on the internal portion of the probe's base. An electrical signal is applied to one crystal at the frequency corresponding to the probe's self-resonance. This electrical excitation causes physical deformation of the crystal which in-turn creates probe vibration. When no material is present around the **VibraRod's** probe, the vibration of the probe is received by the second crystal. This causes physical deformation of the second crystal which generates a voltage

analyzed by the electronic circuitry. With material present at the probe, the vibration is dampened so that the second crystal is not able to generate as high a voltage as when no material is present. The electronic circuitry senses this change and the relay output changes accordingly.

APPLICATIONS

The **VibraRod™** level sensor provides reliable point level sensing in a wide variety of applications for most bulk solid materials. The single-prong vibrating rod principle requires no calibration, is easily setup and eliminates the application problems associated with build-up and clogging between tines on a typical "tuning fork" device. The **VibraRod** is ideal for bulk solids ranging from 3.12 lbs/ft³ (0.05 kg/dm³) with a maximum particle size of about 3/8 inches (10 mm) and is even self-cleaning via vibration in many applications.



TYPICAL APPLICATIONS INCLUDE, BUT ARE NOT LIMITED TO:

| | | |
|----------------------|---------------------|---------------------|
| Chemicals | Clay | Sawdust |
| Grain | Carbon Black | Plastics |
| Sand | Cement | Feed Pellets |
| Rice | Flour | Tobacco |
| Food Products | Fly Ash | Lime |

FEATURES

SINGLE-PRONG PROBE DESIGN

The **VibraRod™** provides a probe design superior to "tuning fork" devices and eliminates problems associated with build-up between tines of "tuning fork" devices. In addition, the **VibraRod's** vibration acts as a self-cleaning effect for most materials, which can further eliminate problems. The reinforced 316 stainless steel rod provides a high level of corrosion resistance suitable for virtually any application.

IMMUNE TO CHANGES

The unique design of the **VibraRod** level sensor makes it immune to changes in many different application variables including:

- ▼ Vessel contents
- ▼ Density of material
- ▼ Particle size
- ▼ Temperature
- ▼ Material composition
- ▼ Dielectric constant
- ▼ Moisture content
- ▼ Pressure and Humidity



NO CALIBRATION REQUIRED

The **VibraRod** level sensor is very easy to use. Unlike RF Capacitance sensors, no calibration is required. Simple switch adjustments for time delay, fail-safe and sensitivity are all that is required to setup and use the **VibraRod** sensor.

SELECTABLE FAIL-SAFE MODE

The **VibraRod** is selectable for high or low fail-safe mode. This allows the user to set the output "state" upon alarm activation and power failure.

LOCAL INDICATION

VibraRod level sensors include a bi-color LED to indicate power and material absence/presence (Ordinary location sensors only).



UNIVERSAL POWER SUPPLY

All **VibraRod** level sensors can be provided in either a high or low voltage design. The high voltage design can be used with 85-265VAC and 120-375VDC. The low voltage design requires either 16-40VAC or 19-55VDC. This allows two power supply ranges to cover all possible requirements.

CHOICE OF HOUSING MATERIALS

A choice of either plastic or aluminum is offered.

CHOICE OF PROBE CONFIGURATIONS

Flexibility for virtually any bulk solids point level application (top or side mounted) is enhanced with a choice of three probe configurations: Standard, Cable Extension and Pipe Extension.

HAZARDOUS LOCATION VERSION

The Standard, Pipe Extended and Cable Extended configurations of the **VibraRod** level sensor (aluminum housing only) can be provided with ATEX hazardous area certification. This allows the **VibraRod** to be used in areas where hazardous explosive dust is present.

AVAILABLE CONFIGURATIONS

STANDARD PROBE

The standard probe is 9-1/4 inches (235 mm) in length and is suitable for both top and side mount applications. It mounts to the vessel with a 1-1/2" NPT or BSP connection.

PIPE EXTENSION PROBE

For high and low level applications that extend beyond the length of the standard probe, the **VibraRod** can be provided with a pipe extension probe. This configuration is intended for top mount applications only. The extension is constructed of 1" stainless steel pipe, which provides structural strength and affords a means to secure the assembly to the vessel. The pipe extension probe is available in lengths up to 10 feet (3 m) in length. The unit mounts to the vessel with a 1-1/2" NPT or BSP connection.

CABLE EXTENSION PROBE

The cable extension probe configuration extends the detection length beyond the standard and pipe extension probes. This version of the **VibraRod** level sensor is for use in top mount applications only and can be used for both high and low level applications. A polyethylene (PE) coated steel reinforced cable is used for the extension and is available in lengths up to 65 feet (20 m). The unit mounts to the vessel with a 1-1/2" NPT or BSP connection.

MECHANICALS

DIMENSIONS ARE SHOWN IN INCHES WITH MILLIMETER EQUIVALENT IN BRACKETS

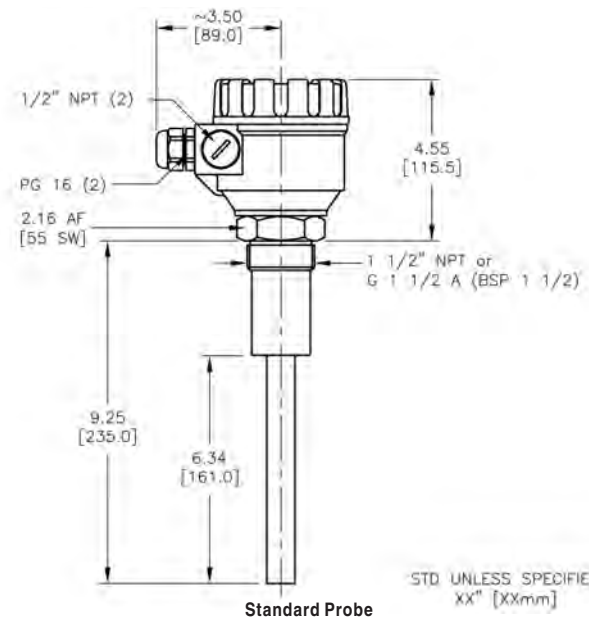

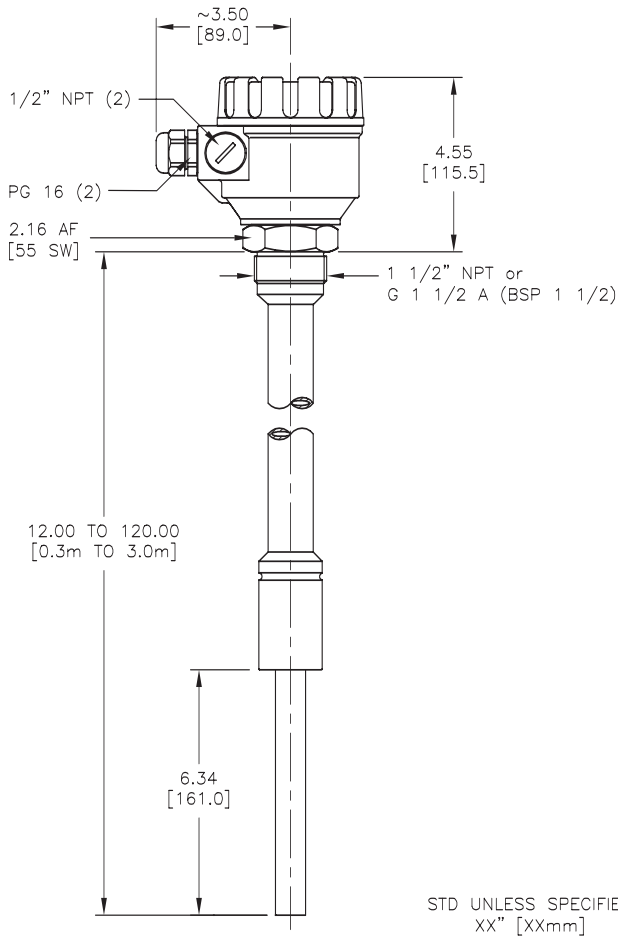

Pipe Extension Probe

STD UNLESS SPECIFIED
XX" [XXmm]

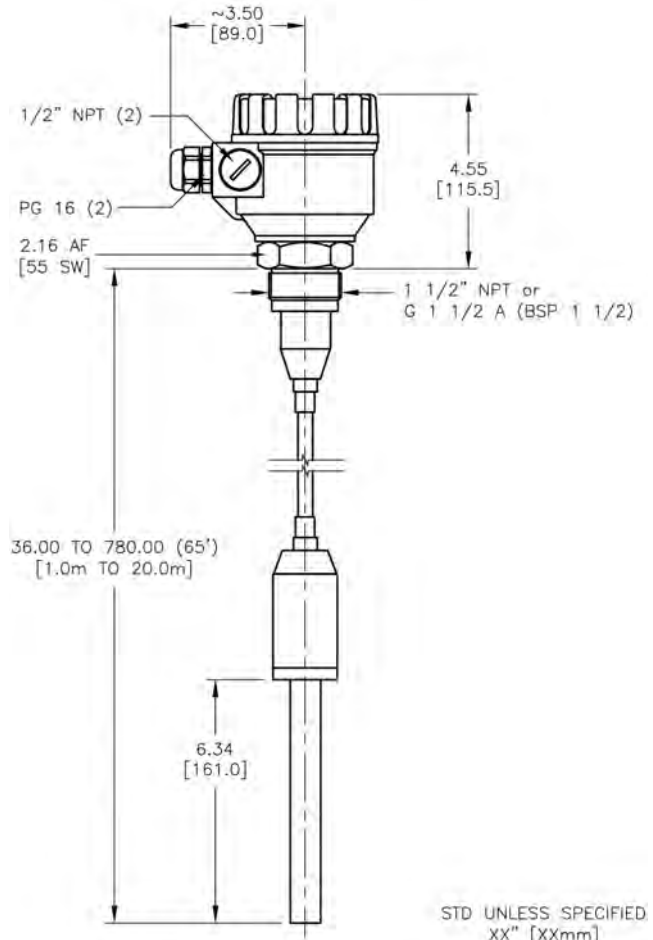

Cable Extension Probe

STD UNLESS SPECIFIED
XX" [XXmm]

ORDERING INFORMATION



MODEL/PROBE CONFIGURATION
 1= Standard probe
 2= Cable Extension Probe (Specify length from 3ft/1m to 65ft/20m)
 3= Pipe Extension Probe (Specify length from 12in/0.3m to 10ft/3m)

HOUSING CONSTRUCTION MATERIAL
 1= Aluminum
 2= Plastic

APPROVALS
 1 = Ordinary Location(North America)
 2 = Ordinary Location(Europe)
 3 = Hazardous Location ATEX

OUTPUT/POWER SUPPLY
 1= Relay (SPDT); 85-265VAC/120-375VDC
 2= Relay (SPDT); 16-40VAC/19-55VDC

PROCESS CONNECTION
 1= 1-1/2" NPT
 2= 1-1/2" BSP



SPECIFICATIONS

| | |
|-------------------------------|---|
| Power Requirements: | |
| High Voltage: | 85-265VAC(50/60Hz) or 120-375VDC |
| Low Voltage: | 16-40VAC(50/60Hz) or 19-55VDC |
| Power Consumption: | |
| High Voltage: | ≤ 2.5VA (AC); 1.2W (DC) |
| Low Voltage: | ≤ 2.5VA (AC); 1.3W (DC) |
| * Process Temperature: | |
| Standard Probe: | -22° to 230° F (-30° to 110° C) |
| Pipe Ext. Probe: | -22° to 230° F (-30° to 110° C) |
| Cable Ext. Probe: | -13° to 194° F (-25° to 90° C) |
| Ambient Temp: | -22° to 140° F (-30° to 60° C) (all units) |
| Output Relay: | SPDT isolated; 8A @ 250VAC max |
| Sensitivity: | 3.12lbs/ft ³ (0.05kg/dm ³) min density (max particle size=3/8in(10mm); Switch Selectable: High (>6.24lbs/ft ³ or 0.1kg/dm ³) or Low (≤ 6.24lbs/ft ³ or 0.1kg/dm ³) |
| Time Delay: | Switch Selectable: On-Delay (when immersed): < 1.8 sec OR 5 ± 1.5 sec; Off-Delay (when free of material): < 2 sec OR 5 ± 1.5 sec Switch Selectable: High or Low |
| Fail-Safe: | |
| Housing: | Powder coated die-cast alum. or Plastic (PBT/Polybutylene Terephthalate fiberglass reinforced); NEMA6, IP67 1-1/2" NPT or G 1-1/2 A (BSP 1-1/2) |
| Mounting Connection: | |
| Pressure Rating: | |
| Standard Probe: | 363psi (25bar) |
| Pipe Ext. Probe: | 363psi (25bar) |
| Cable Ext. Probe: | 87psi (6bar) |
| Conduit Connections: | Two (2) 1/2" NPT and Two (2) PG16 |
| Local Indicator: | Bi-color LED; Red indicates de-energized relay and output "on"; Green indicates energized relay and output "off"; No LED illuminated indicates improper supply voltage or damaged circuitry |
| Probe Material: | |
| Standard Probe: | 316Ti SS (DIN 1.4571) |
| Pipe Ext. Probe: | Probe is 316Ti SS (DIN 1.4571); 1" pipe is 316 or 316Ti (Europe Only; DIN 1.4571); max 10ft (3m) |
| Cable Ext. Probe: | Probe is 316Ti SS (DIN 1.4571) Polyethylene coated, steel reinforced cable; max 65ft (20m) |
| Weight: | |
| Standard Probe: | Aluminum: 4.28lbs (1.94kg) Plastic: 3.44lbs (1.56kg) |
| Pipe Ext. Probe: | Aluminum: 4.28lbs + 0.08lbs/in (1.94kg + 1.4kg/m) Plastic: 3.44lbs + 0.08lbs/in (1.56kg + 1.4kg/m) |
| Cable Ext. Probe: | Aluminum: 4.28lbs + 0.034lbs/in(1.94kg + 0.6kg/m) |
| Approvals: | CE Mark ATEX Ⓜ II 1/2 D IP 65 T (T rating dependent on model, consult factory) (zone 20/21) |

* Influenced by the ambient temperature. Refer to Installation & Operation manual for details.

WARRANTY

Monitor Technologies LLC warrants each **VibraRod™** it manufactures to be free from defects in material and workmanship under normal use and service for two (2) years from the date of purchase. The purchaser must notify Monitor of any defects within the warranty period, return the product intact, and prepay transportation charges. The obligation of Monitor Technologies LLC under this warranty is limited to repair or replacement at its factory. This warranty does not apply to any product which is repaired or altered outside of Monitor Technologies' factory, or which has been subject to misuse, negligence, accident, incorrect wiring by others, or improper installation. Monitor Technologies LLC reserves the right to change the design and/or specifications without prior notice.





44W320 Keslinger Road ▼ P.O. Box 8048 ▼ Elburn, IL 60119-8048 ▼ 800-766-6486 ▼ 630-365-9403 ▼ Fax 630-365-5646
www.flexar.info ▼ www.monitortech.com ▼ monitor@monitortech.com

